

Sensor Bearings for Industrial Machinery

The unitized structure of NSK's sensor bearing consists of a ball bearing with a magnetic encoder to detect rotating speed and rotating direction. The compact size of this bearing enhances further downscaling of associated equipment, and compared to conventional externally mounted sensors, simplifies the assembly process for manufacturers by eliminating the need to make sensor adjustments.

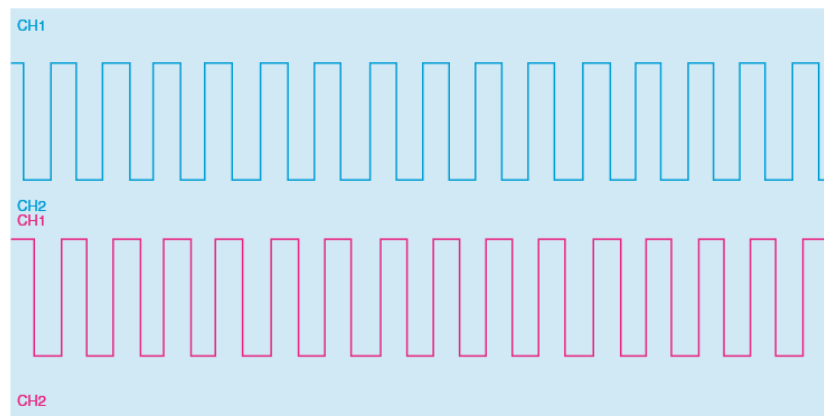

Example of output signals

Features

1. Operational under external magnetic flux
2. Twice as resistant to magnetic flux in comparison with conventional sensors
3. Rotating speed and direction simultaneously detectable
4. Contributes to equipment downscaling

Applications

1. Robots
2. Forklifts
3. Ventilators
4. Elevators/Lifts (freight and passenger)

NOCO SHOP

Email: info@noco-evco.com - Website: <https://www.noco-evco.com/>

Sensor Bearings for Industrial Machinery

Specifications

Bearing: deep groove ball bearing 6206

Dimensions: bore diameter: 30 mm; outside diameter: 62 mm; width: 23.5 mm

Number of pulses: 64 pulses/rotation

Output pulse: channels A and B (phase shift: $90^\circ \pm 45^\circ$)

Pitch accuracy: $\pm 5\%$

Duty ratio: $50 \pm 15\%$

Input power: DC 5 V to 24 V

Output current: less than 20 mA

Operating temperatures: -40°C to 120°C

Dimensions

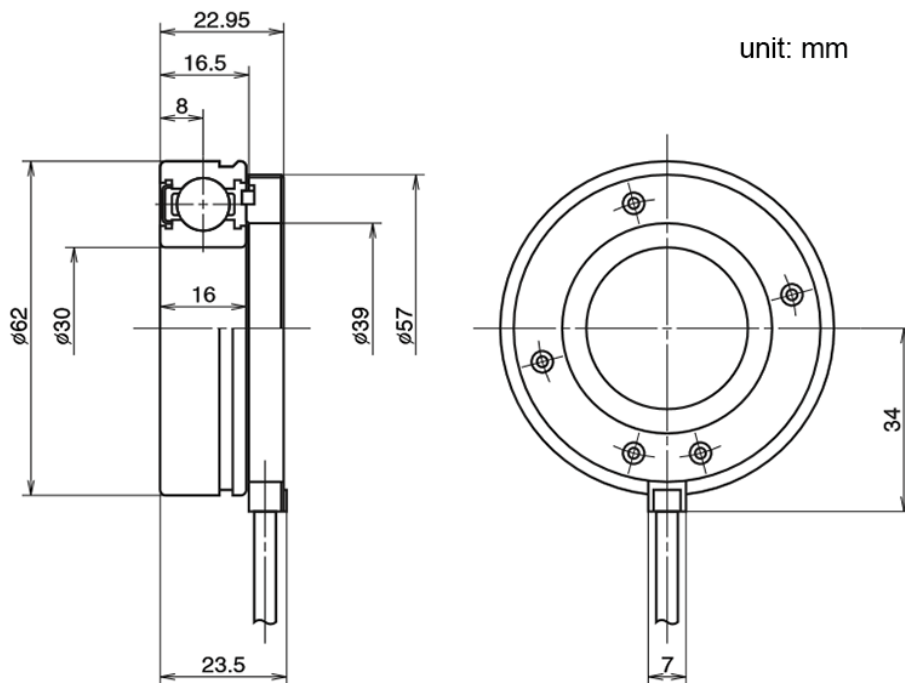

For more application details, please contact: info@noco-evco.com

More information about NSK sensor bearings available on: www.nsk.com

NOCO SHOP

Email: info@noco-evco.com - Website: <https://www.noco-evco.com/>