



The 'E' difference

A significant enhancement to the Curtis AC family, The 'E' models utilize a powerful dual-microprocessor logic architecture to provide improved performance and surpass the requirements of the latest international functional safety standards.

DESCRIPTION

Curtis Models 1236E and 1238E provide advanced control of AC induction motors performing on-vehicle traction drive or hydraulic pump duties. They offer vehicle developers a highly cost-effective combination of power, performance and functionality.

APPLICATION

Designed primarily for use on medium to large material handling vehicles such as counterbalance or warehouse trucks. The Model 1236E is equally suitable for industrial utility vehicles. The larger Model 1238E is also intended for use on all heavy-duty applications such as Tow Tractors and Airport Ground Support Equipment (GSE).

Only Curtis AC can offer:

- **Curtis VCL™—Vehicle Control Language** is an easy to use programming language that allows vehicle developers to write powerful logic functions and create a 'virtual system controller'. Curtis offers customers VCL development tools and training. Curtis also provides a VCL service where Curtis engineers will work with the OEM to create any custom VCL code required.
- **Indirect Field Orientation (IFO) vector control** algorithm generates the maximum possible torque and efficiency across the entire speed range. Advanced Curtis IFO vector control provides superb drive 'feel', improved speed regulation and increased gradeability.
- **Curtis Auto-Tune** function enables quick and easy characterization of the AC motor without having to remove it from the vehicle. Curtis AC controllers are fully compatible with any brand of AC motor.
- **Dual-Drive functionality** is standard, allowing correct control of applications featuring twin traction motors. This function ensures smooth and safe operation, minimal tire wear and correct load sharing between the traction motors at all times.
- **Configurable CANbus** connection allows communication with other CANbus enabled devices. Models 1236E and 1238E are CANopen compatible and provide 20 VCL-configurable CAN 'mailboxes', 6 more than earlier Curtis AC controllers.
- **Integrated System Controller**—More than just a motor controller, they are also powerful system controllers. They feature a comprehensive allocation of multi-function I/O pins for use as analog inputs, digital inputs, contactor coil drivers and proportional valve drivers. In addition to this local I/O, these controllers can use VCL to map and configure the remote I/O available on other CANbus devices, send messages to CAN displays and thus control and monitor the entire system.

FEATURES

Increased Performance, Improved functionality

- Higher performance form, fit and functional replacements for earlier Curtis Model 1236 and 1238 AC controllers.
- CE marked as a programmable safety device under EN ISO 13849-1.
- Models available for 350–800A output at 24–96V system voltages. These are true 2 minute RMS ratings, not short duration 'boost' ratings.
- Enhanced 64MHz micro and additional FLASH memory doubles the available VCL code space and provides more than twice the VCL execution speed.
- Six additional VCL-configurable CAN 'mailboxes' significantly increases CAN master capabilities.
- Advanced Pulse Width Modulation techniques produce low motor harmonics, low torque ripple and minimized heating losses, resulting in high efficiency.

FEATURES continued

Unmatched Flexibility

- Programmable for either traction or pump applications.
- Field upgradeable software.
- Integrated Battery state-of-charge algorithm and hour meters.
- Fully-featured generic software and VCL for typical Warehouse Truck applications is included.
- Comprehensive programming options and VCL allow other applications to be easily supported.
- Curtis hand-held or PC Windows programming tools provide easy programming and powerful system diagnostic tools.
- Integrated status LED provides instant diagnostic indication.

Robust Safety and Reliability

- Dual Microprocessor architecture cross-checks critical circuits, logic, and software functions to ensure the highest possible functional safety performance level is achieved.
- Insulated metal substrate power-base provides superior heat transfer for increased reliability.
- Fail-Safe power component design.

- Reverse polarity protection on battery connections.
- Short circuit protection on all output drivers.
- Thermal cutback, warning, and automatic shutdown provide protection to motor and controller.
- Rugged sealed housing and connectors meet IP65 environmental sealing standards for use in harsh environments.

Meets or complies with relevant US and International Regulations

EMC: Designed to the requirements of EN12895.

Safety: Designed to the requirements of:

EN1175-1:1998+A1:2010

EN (ISO) 13849-1

IP65 Rated per IEC 60529.

UL recognized per UL583.

Regulatory compliance of the complete vehicle system with the controller installed is the responsibility of the vehicle OEM.

FUNCTIONAL SAFETY DATA

Safety Function	PL	Designated Architecture	MTTFd	DC
Uncommanded Powered Movement	d	Category 2	≥36 yrs	≥90%
Motor Braking Torque	c	Category 2	≥12 yrs	≥90%

MODEL CHART

Model	Nominal Battery Voltage (V)	2 Min RMS Current Rating (A)	S2-60 Min RMS Current Rating (A)
1236E-44XX	24-36	400	175
1236E-45XX	24-36	500	240
1236E-54XX	36-48	450	205
1236E-55XX	36-48	550	250
1236E-64XX	48-80	350 (1 min)	100
1238E-46XX	24-36	650	300
1238E-48XX	24-36	800	355
1238E-56XX	36-48	650	295
1238E-64XX	48-80	450	155
1238E-65XX	48-80	550	190
1238E-66XX	48-80	650 (1 min)	195
1238E-75XX	72-96	550	175
1238E-76XX	72-96	650	200

MODELS 1236E / 1238E

SYSTEM ACCESSORIES

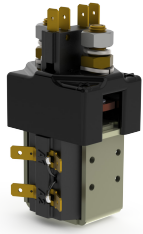

Curtis/Albright offers a full line of UL recognized DC contactors engineered for outstanding performance and durability on in-vehicle applications.



The Curtis Model 1222 is an AC induction motor controller for 'steer by wire' electric power steering systems and is the ideal partner for the 1236E/1238E on vehicles such as reach trucks, order pickers, stackers and other similar industrial vehicles.

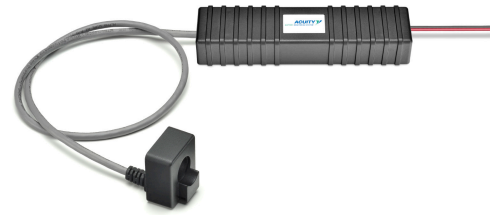

The Curtis Acuity Battery Monitoring system is a device that mounts directly to the vehicle battery. It measures, records and transmits battery performance data over the vehicle's CAN network throughout the battery's life.

Contact Curtis to obtain the VCL Vehicle Control Language compiler and development tools.

CONNECTOR WIRING

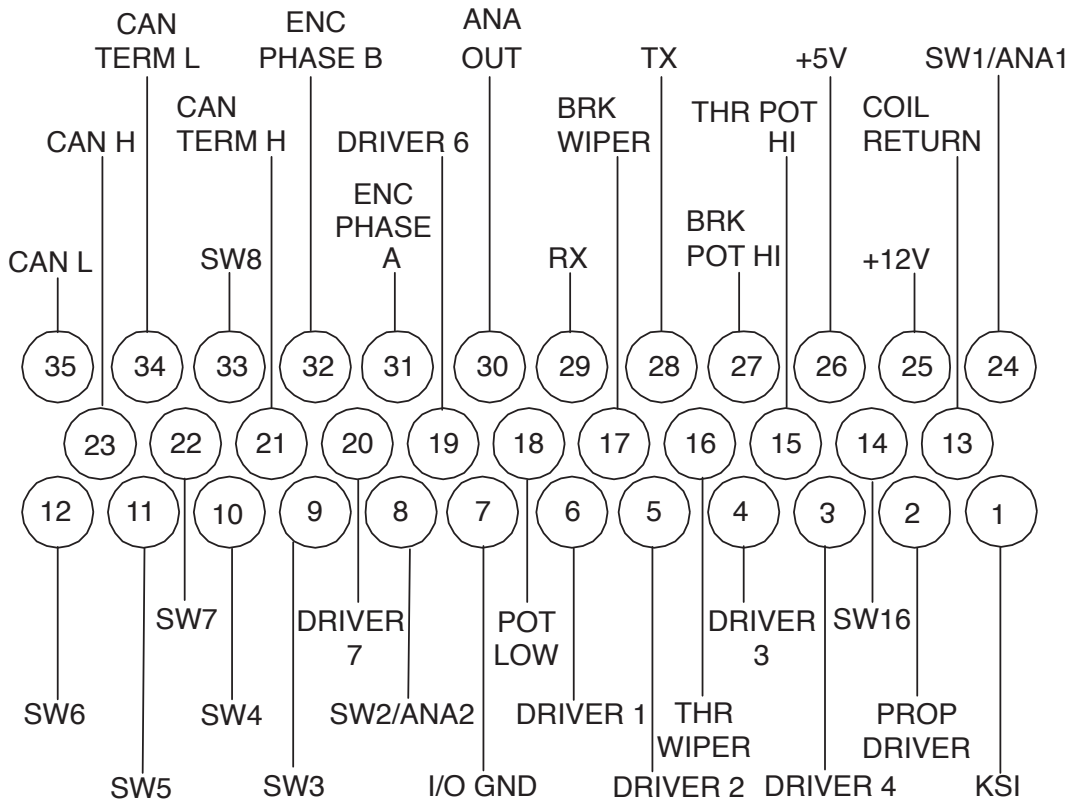

MODELS 1236E / 1238E

DIMENSIONS mm (typical)

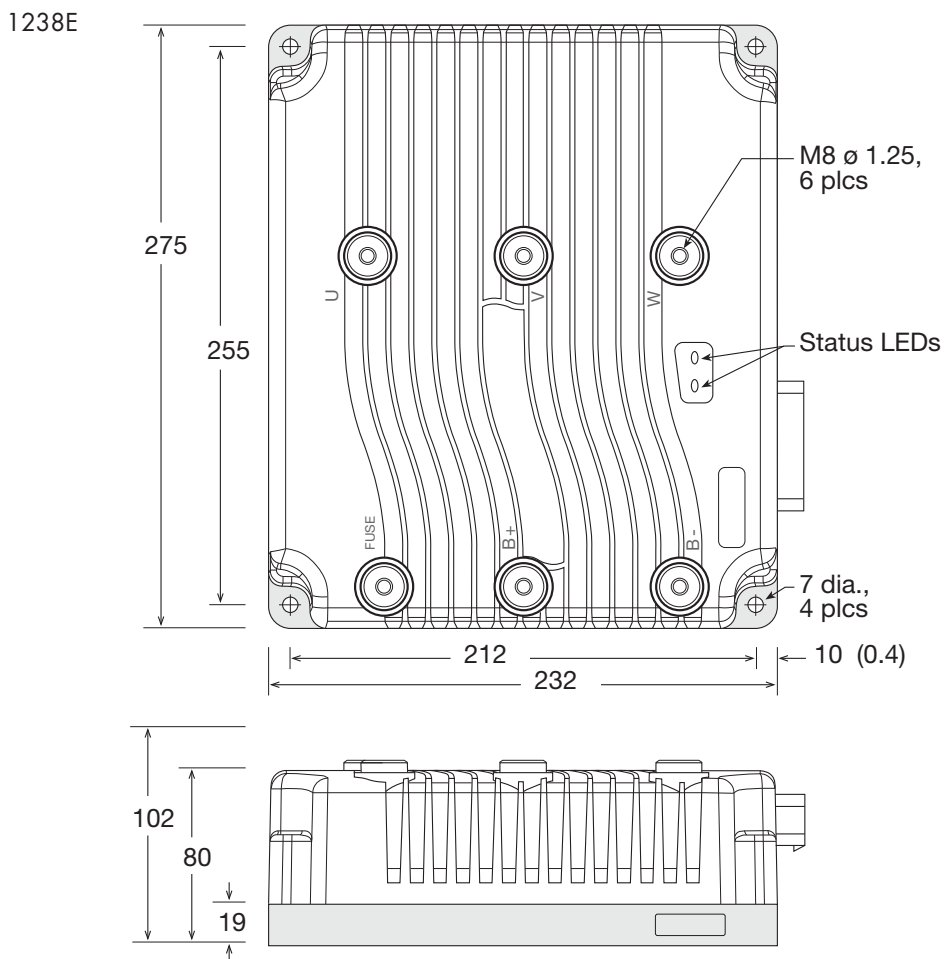
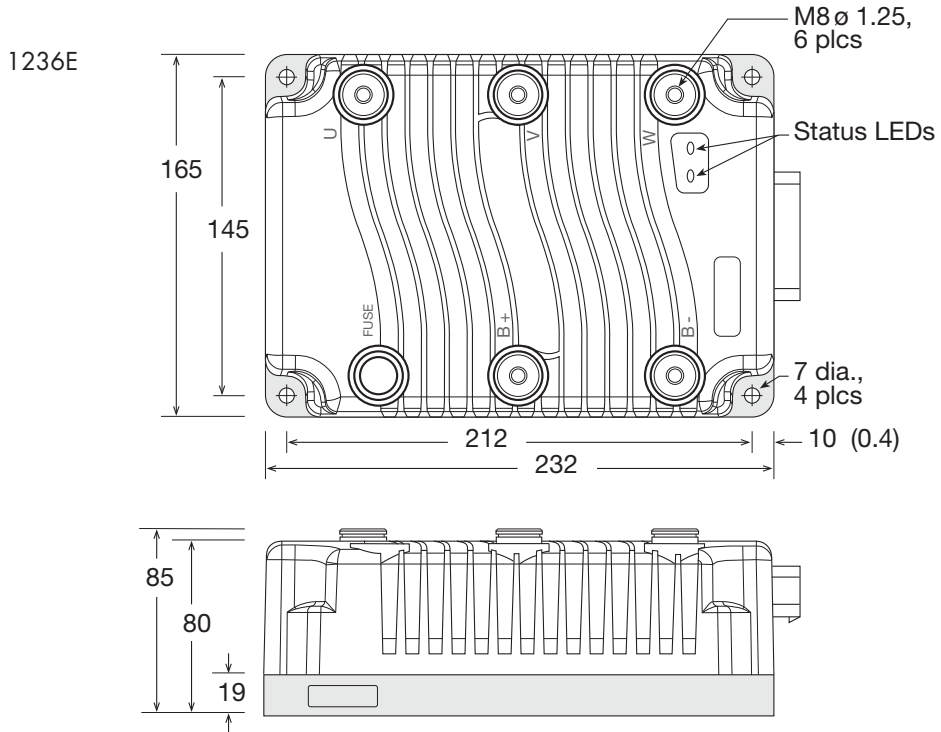

MODELS 1236E / 1238E

TYPICAL WIRING

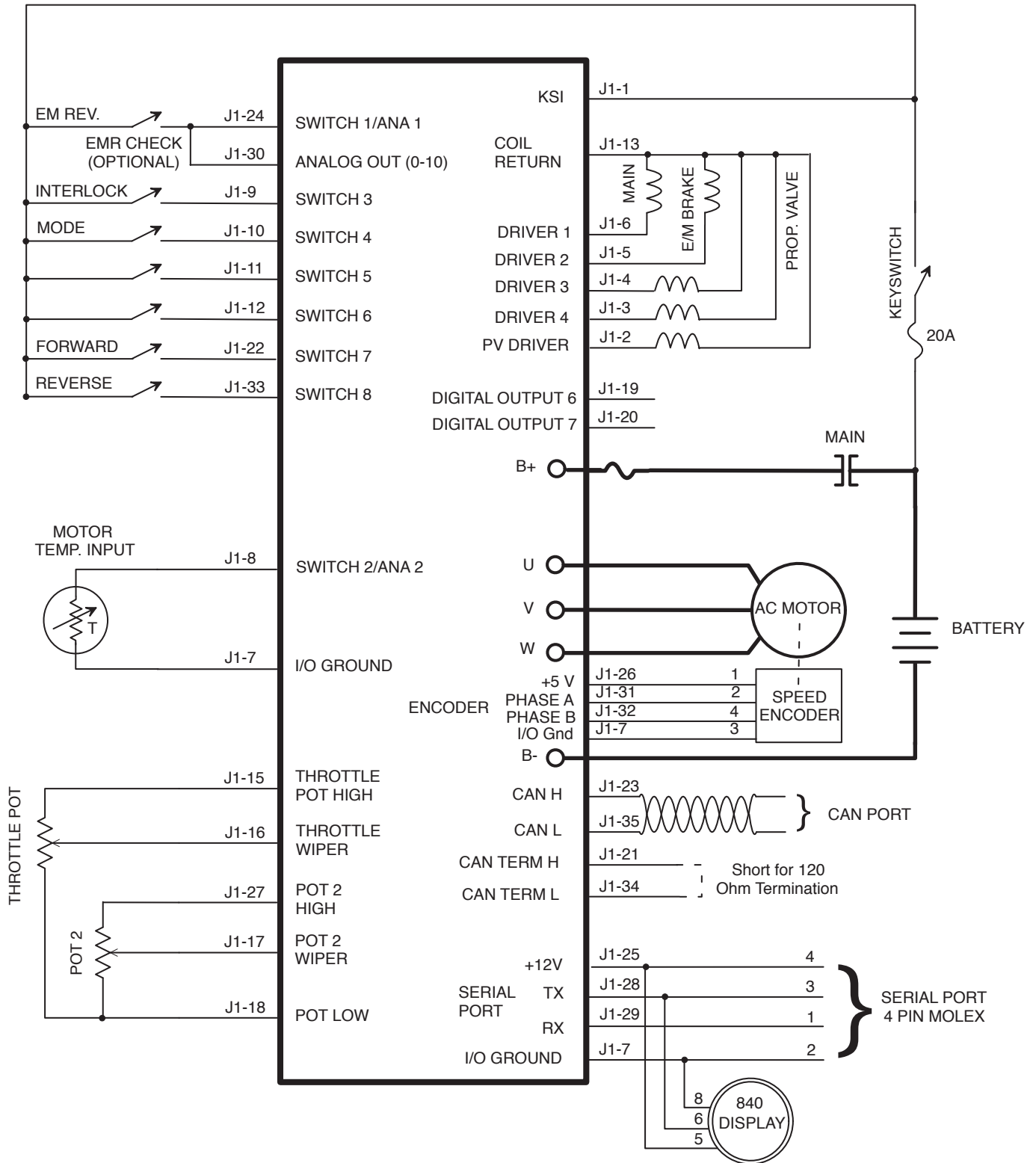

WARRANTY Two year limited warranty from time of delivery.

The Curtis Difference
You feel it when you drive it